



C
E
M
E
N
T
B
U
L
K



■ CEMENT BULK TANKER

Specifications

| | |
|--------------------|---|
| Capacity | 16.88 cubic meter |
| Overall Length | 9,250 ± 15 mm |
| Width | 2,100 ± 15 mm |
| Height | 3,980 ± 15 mm |
| Fifth Wheel Height | 1.28 m |
| Axles | Double 2x9,500 kgs |
| Tires | 8 x 12R24" |
| Axle Spacing | 1.56 m |
| Weight | 2,200 kgs (Approx.) |
| Pump lines | Suction: 152mm (6") Discharge: 127mm (5") Flow Rate at 64 psi: 3.7 m ³ /min (23bpm) Maximum closed in pressure: 0.49 MPa (70 psi) |

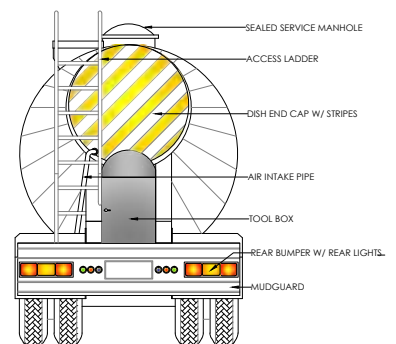

REAR ELEVATION

Shot Blasting & Painting

All steel parts shall be shot blasted and painted with twin coats of primer and finish enamel paint. Color can be as per customer choice.

(All given above specifications may undergo change as a result of continuous product improvement.)

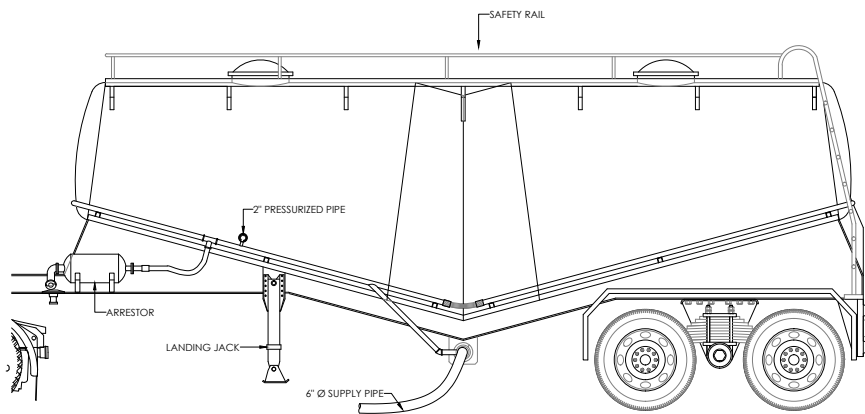

SIDE ELEVATION

TOP VIEW

